

## THE DG 300 MARK 2 5-SPEED TRANSAXLE GEARBOX UNIT

The Mark 2 DG300 Gearbox has five forward ratios and reverse. It is designed for use with rear engine competition cars having a capacity of up to 4% litres.

Only one final drive ratio is used. Since the drive is indirect at all times, any change in ratio can be made through the gearbox. The drive is taken from the clutch shaft to the spiral bevel final drive via straight cut gears. Gear change is effected by non-synchronised face dogs. Ratios can be changed without removing the unit from the chassis, and all requirements can be met from our extensive range of gears. All ratios except bottom are inter-changeable, and may be arranged in any order.

The differential and crown wheel assembly is mounted on two taper roller bearings located in the side plates and adjustable to correct pre-load by shims. Output shafts are also mounted in the side plates, and lip oil seals are fitted.

The gears run directly on caged needle roller bearings, and each gear and bearing revolves as an assembly. Heat treated nickle-chrome steel is used for all gears and shafts. Selector forks are cast in aluminium bronze, and

casings in magnesium alloy.

The differential is of Limited Slip design, the unit normally supplied being the Cam and Pawl type.

The gearbox unit is lubricated by oil splash, and the final drive by pump. The pump is located in the main case, and is fed via a filter which can be withdrawn from the outside of the case. The oil is piped out of the main case on the righthand side and returns via external piping, thus providing for the fitting of an oil cooler. The latter is strongly recommended to ensure that oil temperature does not exceed its maximum of

The gear change rod is mounted low down on the right hand side. The clutch is operated by steel fork and push-rod - accepted as the simplest and most reliable system, especially with monocoque chassis. The push-rod is actuated from a slave cylinder mounted on the side of the main case.

The general configuration of the DG 300 Mark 2 Series provides the maximum utilisation of power allied to minimum weight for the power required to be transmitted.

# Technical Specification

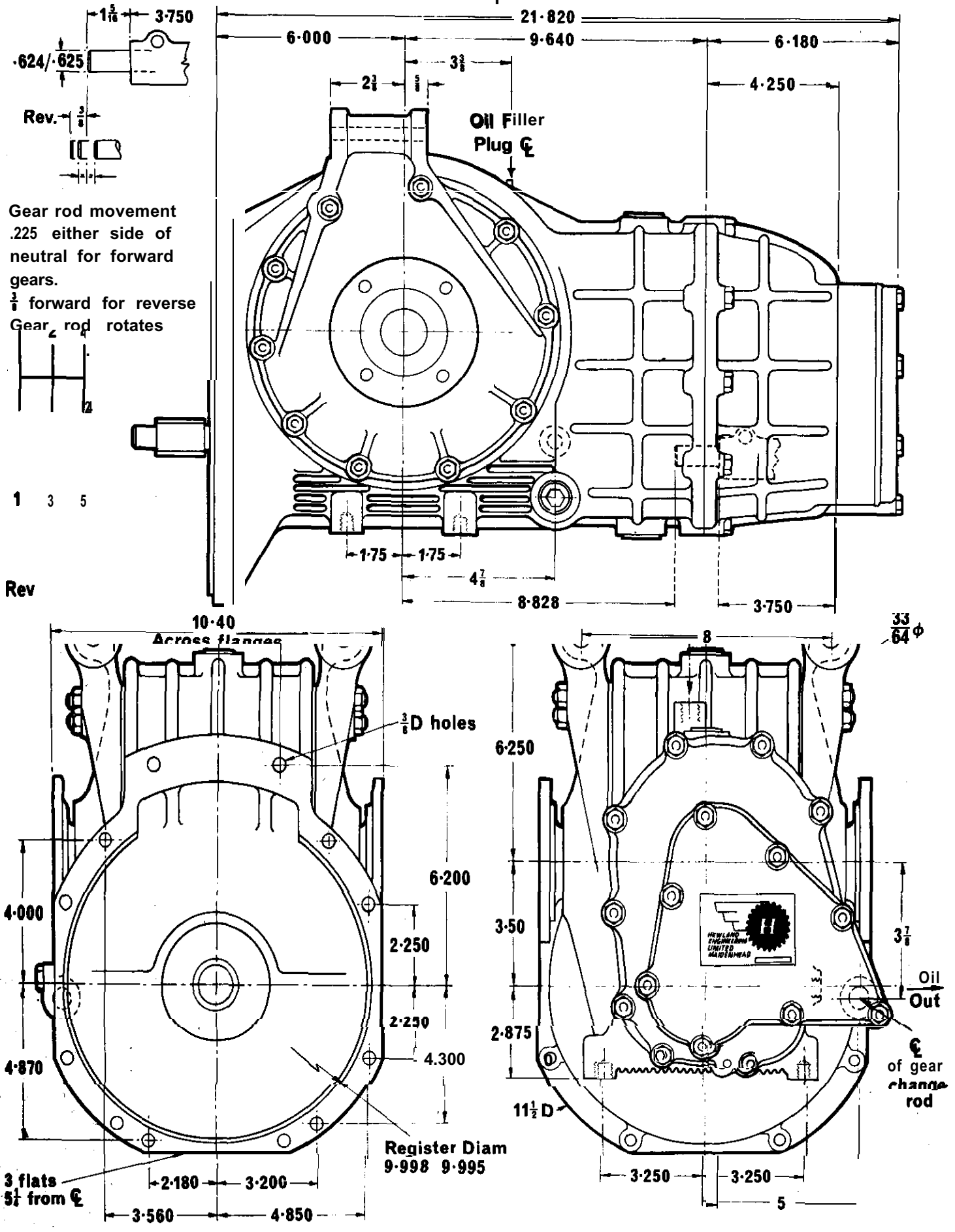

Dimensions in inches

# Index

	PAGE		PAGE
Backlash, adjusting . . . . .	15, 16	Main case and Diff. Compartment	9
Bearing Carrier (Main) . . . . .	5	Oil, capacities and type . . . . .	3
Bearing Carrier (Clutch Shaft) . . . . .	9	Oil pump . . . . .	13, 18
Bearings		Oil Filter . . . . .	8, 13
Layshaft and pinion, front	9, 15	Pinion . . . . .	9, 13, 15
Layshaft and pinion, tail	5	Plungers . . . . .	5
Clutch Rings . . . . .	5	pre-load, adjusting . . . . .	15
Clutch Shaft . . . . .	9	Reverse Idler Gear . . . . .	9
Crown Wheel . . . . .	13, 15	Selector Finger . . . . .	5, 9
Crown Wheel & Pinion, setting up	15	Selector Forks, removal . . . . .	5
Differential Unit, Removal	9	Selector Forks, setting up . . . . .	7
Differential Unit, Dismantling	13	Selector heads . . . . .	5, 7
End Case . . . . .	5	Selector Rods . . . . .	5, 7
Filter . . . . .	13	Setting up +	
Gearbox Unit . . . . .	5	Crown Wheel & Pinion . . . . .	15
Gear Ratios, changing . . . . .	5	Selector Forks . . . . .	7
Hubs . . . . .	5, 7	Side Plates, removal . . . . .	9
Layshaft . . . . .	7	Side Plates, Dismantling . . . . .	13
		Technical specification . . . . .	2

## General notes on maintenance and overhaul

Only genuine Hewland spares should be used as replacements. These are manufactured in our own workshops to the fine tolerances necessary, and rigorously inspected and tested:

New nuts and gaskets should always be used on re-assembly.

When warming the outside of the case, keep the blowlamp moving. Do not overheat. Test with a spot of moisture, which will bounce off when the case is hot enough.

When refilling with oil, put half the quantity into each filler hole. Never put all the oil in one oil sump.

	DG 300 Mark 2
Weight	118 lbs
Oil Capacity	3% pints
Type of Oil	S.A.E. 80 or 90



# The Gearbox unit

## REMOVING THE UNIT

### END COVER

1. Remove the eight 5/16 UNF Nyloc nuts and washers from the end cover. Take off cover and gasket.
2. Remove the split pins from the castellated pinion and layshaft nuts.
3. Push the heads of the two outside selector rods, thus engaging the gears. This locks the gear box by engaging 2 gears.
4. Remove the pinion nut, (left hand thread) and slacken off the lay shaft nut, (conventional right hand thread)
5. Now withdraw the two outside selector rods, to disengage the gears.

### BEARING CARRIER

1. Remove the ten 5/16 UNF nuts and washers.
2. Using a plastic mallet, tap the bearing carrier and remove it from the main case, complete with lay-shaft assembly and gear train. Support the gears, hubs and clutch rings with the hand, as they come off the pinion.

The gearbox unit is now completely removed.

Replace in reverse order to above.

## CHANGING GEAR RATIOS

When changing a gear ratio, take off the slack-

ened layshaft nut and remove the layshaft from the bearing carrier. Gears are exchanged in pairs - one from the layshaft and one from the pinion shaft. Each gear is etched with two sets of numbers. The first is the number of its own teeth. The second is the number of teeth on its mating gear.

It is essential that gears should be correctly paired according to these numbers.

## STRIPPING THE GEAR TRAIN

1. Remove hubs, clutch rings and gears. Wash and inspect for wear and cracks, giving particular attention to the clutch rings.
2. Examine forks for heavy or uneven wear, and test for excessive play between forks and clutch rings.
3. If forks are not to be stripped, check that nuts are tight and properly tabbed. Continue stripping.

### TO REMOVE SELECTOR FINGER HOUSING (5)

4. Remove selector finger housing by:-
  - (1) Remove bung, spring and plunger, (16, 17, 18) from the selector finger housing and withdraw selector finger. (38)
  - (2) Undo 5/16 UNC Allen cap screw
  - (3) Undo 5/16 UNF Nyloc nut inside housing
5. Remove gasket from bearing carrier.
6. To remove forks, knock back locking tabs (52) and undo nut (53). Remove all three sets and lift off forks (49, 50, 51).

7. Undo the three allen cap screws (36) and take out the to Selector Rod Springs and balls (35 & 34). Then take out the three Selector Rods, one at a time, followed by the bottom balls and springs.
8. Undo the 3/8 UNC allen ca screw (44) and push out the locking slugs. (43)
9. Inspect pinion and layshaft tail bearings and renew if necessary. To remove, warm up surrounding area. N.B. In layshaft bearing check for wear on steel sleeve in layshaft bearing and renew if necessary.

Re-assemble in reverse order **to above, subject to the following:-**

10. When replacing bottom balls and springs, set up to correct height. About one-third of the ball should be exposed. Continue by inserting locking slugs and selector rods, then top balls and springs.
11. Any hub renewed should be identical in length with the original. If replacing all hubs, or main bearing carrier, check that overall length of pinion assembly has not been altered. Clearance is essential to avoid overheating and seizure, but too much clearance will cause excessive wear.

Setting up the selector forks - overleaf

# GEARBOX PARTS LIST

ILLUS. No.	DESCRIPTION	QTY	PART NUMBER
Not illus	Gearbox Complete Std		DC300
Not illus	Gearbox Complete Alternator Drive		DG300A
A1	5/16" UNF Nyloc Nut	30	FT201 3
A2	5/16" Flat Washer	30	FT2027
A3	End Cover		DG204
A4	Gasket End Cover		DG260
A5	Selector Finger Housing		DG203
A6	Gasket Selector Finger		DG261
A7	Nut Layshaft		DG236
A8	Split Pin	2	DG2302
A9	Bearing Layshaft		LG2343
A10	Bush		LG2292
A11	Stud	7	FT2026
A12	Bearing Carrier		DG202
A13	Screw		FT203
A14	Spring		FT2034
A15	Ball		FT2033
A16	Plunger		DG2030
A17	Spring		FT2032
A18	Plug		FT2035
A19	Thrust Washer		DG2345
A20	Spacer		DG2346
A21	Layshaft Std		DG234
A21	Layshaft with Integral 1st Gear		DG234A
A22	Reverse & First Sliding Gear		DG23
A23	Hub Front		DG226
A24	Needle Bearings	5	DG226
A25	Clutch Ring	2	DG232

ILLUS. No.	DESCRIPTION	QTY	PART NUMBER
A26	Hub Centre		DG227
A27	Hub Rear		DG228
A28	Inner Track 5th Gear		DG229
A29	Thrust Washer		DG2294
A30	Stud		FT2025
A31	Bearing	2	DG229
A32	Nut		DG230
A33	Spacer		DG203 IO
A34	Balls : Steel	6	FT202
A35	Spring	6	FT2022
A36	Screw	3	FT 2023
A37	Screw		FT203
A38	Selector Finger		FT252
A39	Bush 5/8"	2	FRO 3 6
A40	'0' Ring		FT2037
A41	Plate		FT2038
A42	Screws-	4	FT2039
A43	Plungers	2	FT2024
A44	Screws		FT2028
A45	Selector Rod 1st & Reverse		DG246
A46	Selector Rod 2nd /3rd		DG247
A47	Selector Rod 4th/5th		DG248
A48	Adjusting Spacer	3	FT2463
A49	Selector Fork   St/Reverse		DG249
A50	Selector Fork 2nd/3rd		DG250
A51	Selector Fork 4th/5th		FT251
A52	Tab Washer	3	FT2461
A53	Nut	3	FT2462

## SETTING UP THE SELECTOR FORKS

Extreme accuracy in setting up is imperative to ensure that gears engage freely, and to avoid uneven or excessive wear. The use of a Hewland Forksetting Jig is strongly recommended. Designed specifically for DG 300 it will save costly setting up time and vastly reduce the possibility of error. (Fig. 1)

*Note that when two layshaft gears run together, their chamfered sides must face each other. (See diagram A)*

1. Warm the case and drop in the pinion tail bearing as described above.
2. Place the jig in a vice. Slide the hubs, with top gear and thrust washer, on to the dummy pinion.
3. Attach the bearing carrier to the jig, using temporary nuts.
4. Tighten the pinion nut. Then check for correct clearance on top gear. (.008" to .010")
5. Remove from jig. Fit selector forks to rods, with nuts and washers.
6. Build up the hubs, gears and clutch rings, and slide them back on to the setting jig.
7. Adjust the forks individually. Correct positioning required that:-
  - (a) The clutch ring should be centred on its hub, between the two gears.
  - (b) The clutch ring should engage fully with either gear.
  - (c) When fully engaged with either gear there should still be 0.005 clearance between the gear and clutch-ring faces.

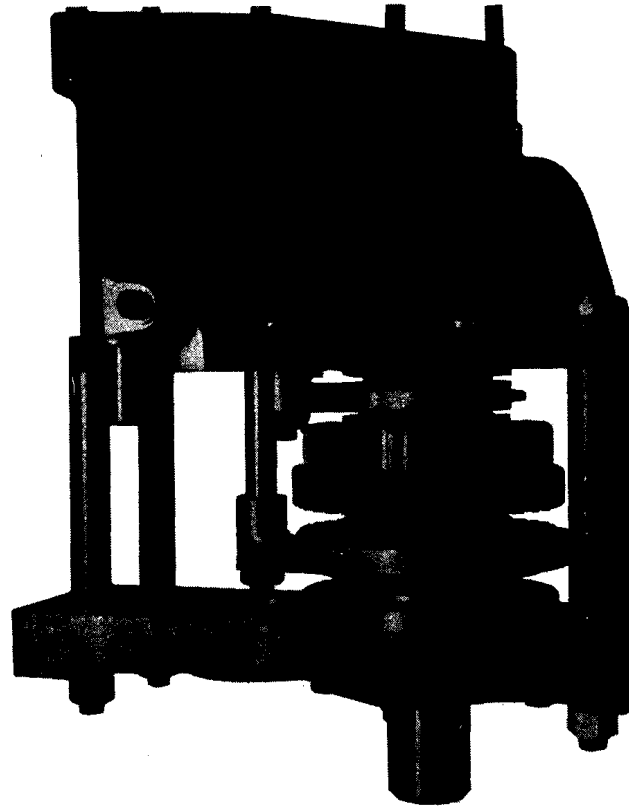

Fig. 2. The Hewland Forksetting Jig

- (b) The clutch ring should engage fully with either gear.
- (c) When fully engaged with either gear there should still be 0.005 clearance between the gear and clutch-ring faces.

When satisfied with the set-up, continue as follows:-

8. Tighten all three selector rods using new nuts and tabs, at the same time, make sure that the selector rod heads are correctly aligned, and that there is clearance between

REMOVE FROM JIG

9. Warm up surrounding area and put in layshaft bearing. Build up the complete layshaft assembly with gears, spacers and thrust washer. Replace in bearing carrier
10. Put the complete set up back into the jig. Re-check all clearances. Test all movements. When satisfied, take from jig and bolt  $\Pi$  onto the gearbox, using a jointing compound.
11. Tighten the nyloc nuts around the bearing carrier. Replace nuts on pinion, layshaft and tighten using torque spanner. Put in split pins.
12. Replace the selector finger housing and selector finger, renewing gasket (6). Put in new gasket (4) and replace the end cover.

*The correct torque is 115 ft.lbs for pinion nut, and 80 ft.lbs for layshaft nut.*

# The Main Case and Differential Compartment

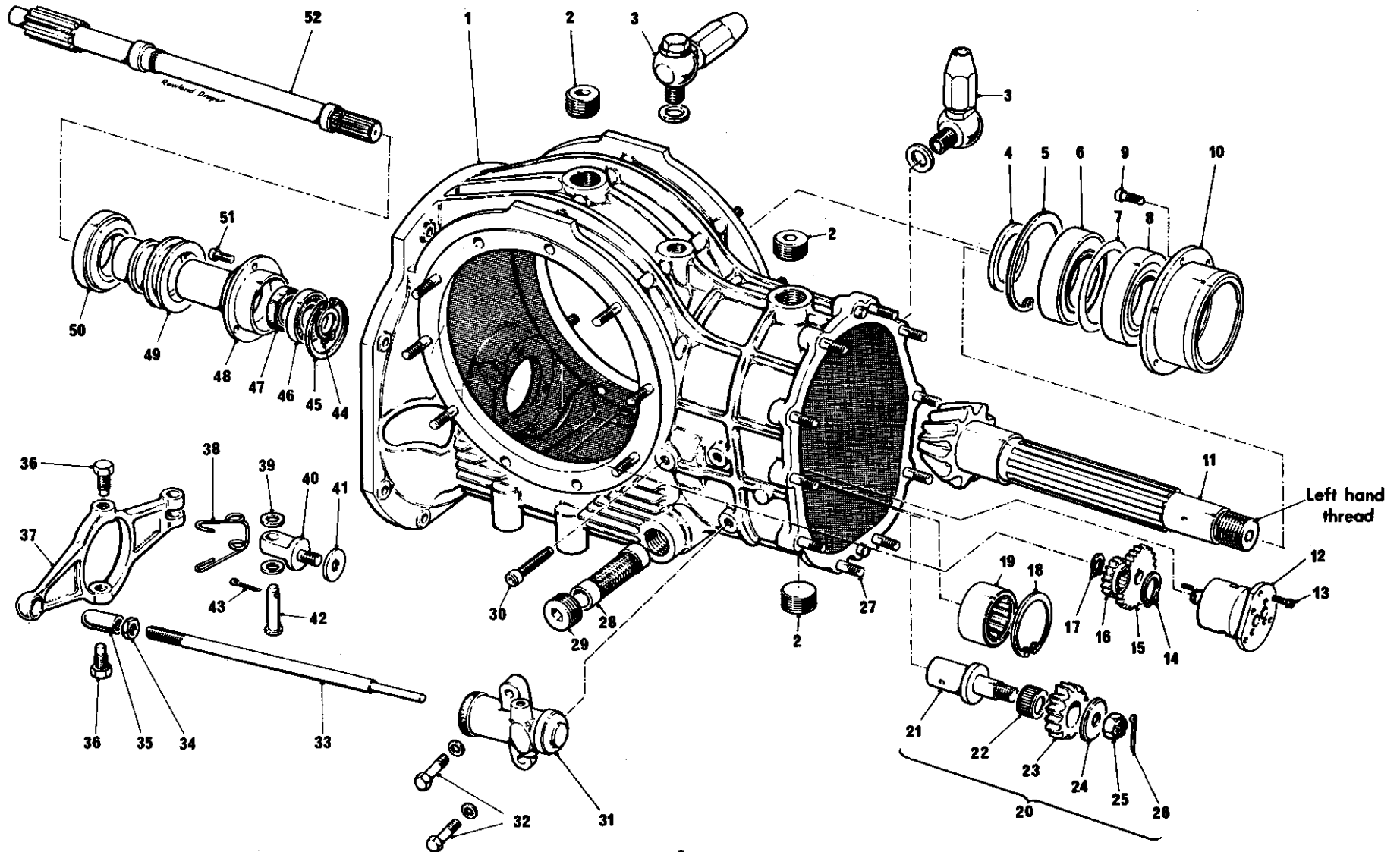

# The Main Case and Differential Compartment

## Removal and replacement of units and assemblies

### DIFFERENTIAL AND DRIVE

1. Take off slave cylinder (31) complete with clutch push-rod, by removing the two bolts and washers.
2. Take off the left-hand side plate, having first removed the 5/16 UNF Nyloc nuts and washers and 3/8 UNF Nyloc nuts of the 4 tie bars. Loosen with light blows from a plastic mallet.
3. Support the complete differential assembly on a hammer shaft and lift it out of the main case.
4. Remove the right-hand side-plate.

Replace in reverse order to **above**.

### CLUTCH SHAFT

1. Unhook the spring (38) from the clutch fork clevis pin, enabling the fork to swing free.
2. Slacken off the top and bottom swivel pins (36) and slide the thrust bearing (50) and bearing carrier (49) off the end of the clutch shaft. -
3. Remove the clutch fork (37) after taking out the split pin and clevis pin.

4. Remove the four 1/4" UNC allen cap screws (51). Slide out complete clutch shaft assembly.
5. Remove small circlip and oil pump driver gear (16). Remove second circlip and press clutch shaft out of spigot housing.
6. Remove the large circlip (45), then the bearing and the oil seal (46 & 47)

Re-assemble in reverse order to above, and also:-

7. Fit a new oil seal (47). Replace any worn parts, giving particular attention to the bearing.
8. When bolting the spigot to its housing, put a smear of locking fluid on the four allen cap screws and jointing compound on spigot face.
9. Check that the bearing carrier rotates freely after tightening down the two swivel pins (36)

### PINION REMOVAL

To remove the pinion proceed as follows:-

1. Remove the 6/14 UNC allen cap screws (9) and warm up the outside of the main case (1).

2. Remove the pinion and housing bearing carrier (10) complete, through the side plate.
3. Take out the Idler gear by removing the split pins (26) and locking nut (25). Now slide off Idler spigot.

### OIL PUMP

Remove the circlip that retains the driven gear and remove gear and woodruff key cap screws and slide out pump unit. To dismantle pump, see page 13.

### LAYSHAFT BEARING

The layshaft bearing is removed by warming the outside of the case, having first taken out the circlip. This bearing will be damaged by removal, and should NOT be disturbed unless it has to be renewed.

Wash and inspect all parts. Wash out main case to remove sludge. Ensure that no small metallic objects or particles have been left in the case.

# MAIN CASE AND DIFFERENTIAL PARTS LIST

ILLUS. No,	DESCRIPTION	QTY	PART NUMBER
C1	Maincase		DG201
c2	Oil Filler Plug	3	F-t-201 I
c3	Banjo Union Complete	2	LG2262
c4	Pinion Spacer		DG2222
C5	Circlip		LG2 2048
C6	Bearing Roller Type		DC2221 A
C7	Shim		DG2231
C8	Pinion Bearing Ball Type		DG2221 B
C9	A lan Cap Screw	6	FG2233
C10	Housing		DG.223
C11	Crown Wheel & Pinion 11 .38 ratio		DG221
C11	Crown Wheel & Pinion 9.31		DG221 A
C11	Crown Wheel & Pinion 8.31		DG221 B
C12	Oil Pump Assembly		DG265
C13	Screws	3	DG2651
C14	Circlip Clutch Shaft		DG2651 0
C15	Gear Oil Pump		DG2657
C16	Gear clutch Shaft		DG2659
C17	Circlip		DG2658
C18	Circlrp		DG2342.
C19	Bearing		DG234i
c20	Reverse Idler Assembly		FT237
C21	Reverse Idler Spigot		FT2373
c22	Bearing		FT2372
C23	Gear		FT2371
C24	Was her		FT2374
C25	Nut		FT2375

ILLUS. No.	DESCRIPTION	QTY	PART NUMBER
C26	Split Pin		FT2378
C27	Stud	10	FT2014
C28	Oil Filter		LG266
C29	Plug		LG2661
c30	Screw		DG2376
C31	Slave Cylinder		FT2582
C32	Bolts	2	F T2583
c33	Push Rod		LG258
c34	Nut		FT2581
c35	Push Rod End		F R 5 9
C36	Swivel Bolt	2	FT256
c37	Clutch Fork		DG254
C38	Spring		LG2584
c39	Was hers	2	- - -
c40	Fulcrum		FT255
C41	Was her		DG2551
c42	Clevis Pin		DC257
c43	Split Pin		DG257 I
c44	Circlip		F R390
c45	Circlip		FT2441 0
C46	Bearing		FT24412
c47	Oil Seal		FT2441 I
C48	Spigots, Types to suit most competitive Engines.		Price and
c49	Bearing Carrier. Ditto		availability or application.
c50	Thrust Bearing		FT2451 I
C51	Screws	3	FT24413
C52	Clutch Shafts. Types to suit most competitive engines. Price and availability on application.		

# Stripping the Sub-assemblies

See **overleaf** for drawing  
and instruction

# Back Axle Unit

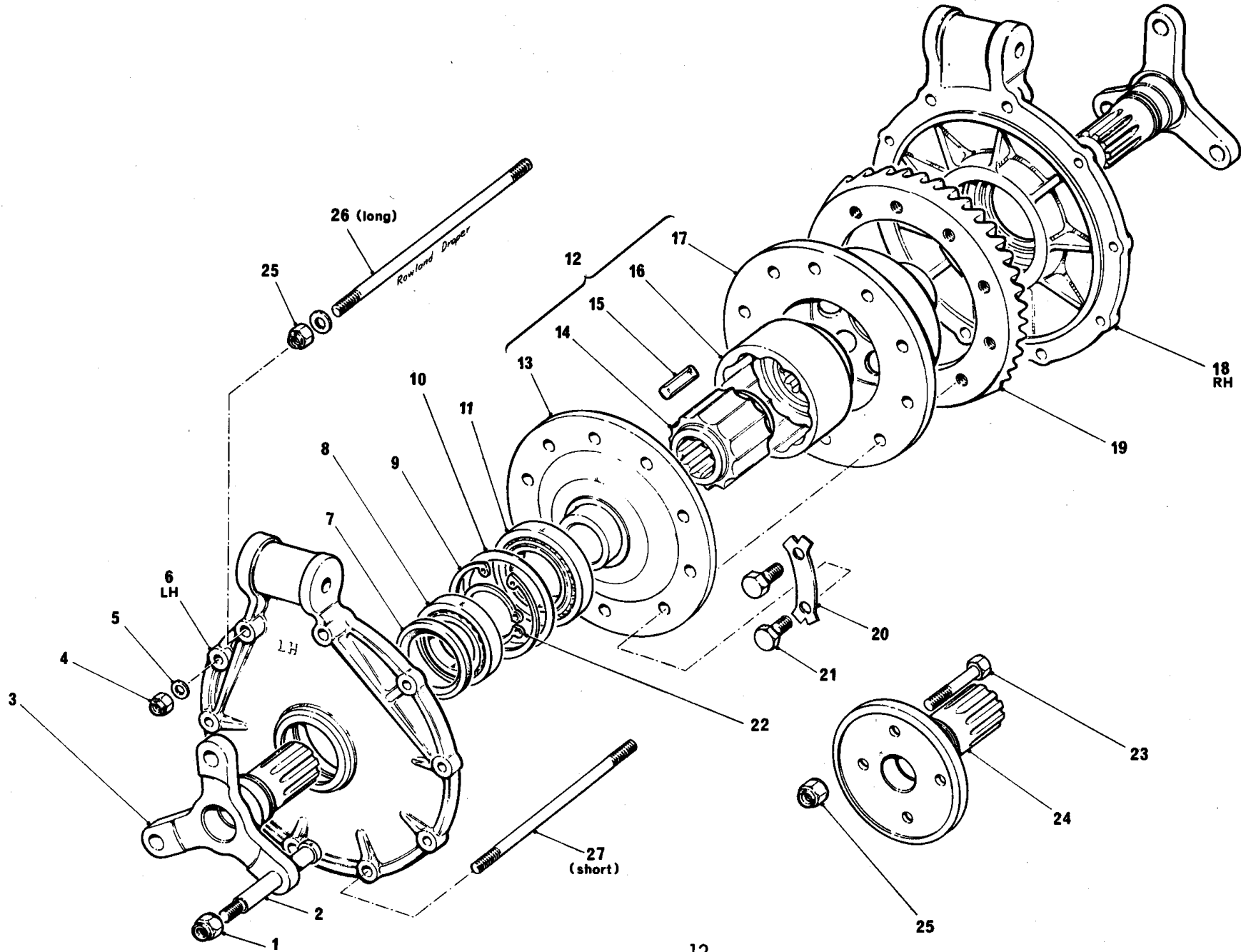

# Stripping the Sub-assemblies

## DIFFERENTIAL

The following instructions apply to the Cam-and-Pawl type Differential DG 300 gearboxes.

1. Bend back the tabs (20), remove the bolts (21) and take off the crown wheel (19).
2. Remove in turn the outer housing (17), outer cam track (16) and inner cam track (14).
3. Remove the eight plungers (pawls) (15) from the plunger carrier (13).
4. Wash and examine for wear or damage, giving particular attention to pawls, and profiles of the cam tracks. Make certain that:-
5. The splines of the inner cam track are towards the drive shaft (3), diagram (B).
6. New bolts and tabs are used for the crown wheel. Tighten with a torque spanner to 75 ft.lbs. Smear bolts with locking fluid.

*N.B. On re-assembly use a good quality grease to lubricate the inner cam track bearing surfaces. We recommend the use of 'Moly-slip' grease for this purpose.*

**Re-assemble in reverse order to above.**

## FINAL DRIVE

Left-band Side Plate

1. Remove the drive shaft circlip (22) and knock out the shaft (3).

2. Support the side plate on fire bricks and warm it, having first covered the oil seal (7) with a block of metal for protection. The outer track of the differential bearing (11) and the shims (10) should now drop out.

3. Remove the large circlip (9) which retains the side plate bearing (8) and oil seal (7), so that both can be withdrawn.

Right-hand Side Plate

Follow the same procedure as above.

Re-assemble in reverse order to above fitting new oil seals if **necessary**.

## OIL PUMP

This unit is extremely sturdy and simple in design. It operates at far below its maximum rating and is unlikely to suffer serious wear. To clean it and inspect gears and body for possible scoring, remove the four allen. cap screws (19) and take off the pump cap (18).

When re-assembling, make sure that the driving shaft (16) is nearest the flat side of the cap.

## OIL FILTER

Remove filter plug (29) and filter (28) clean-Renew if required.

## NOTES ON RE-ASSEMBLY TO THE MAIN CASE

Replace the units and sub-assemblies in the reverse order to which they were dismantled, with special attention to the following:-

1. Slide the oil pump home, then push the splined end of the shaft (16) through the driven gear (12). Take care to replace the woodruff key (14) and circlip (10). Secure it from the back with the three allen cap screws (13 on main assembly) using a smear of locking fluid.
2. When replacing the filter bung (28), do not over-tighten or you may collapse the filter. It should be 'just possible to turn the filter, using slight hand pressure.

## TO REMOVE PINION FROM BEARING CARRIER ASSEMBLY

1. Place the whole assembly under a hydraulic press whilst still in position on the pinion and press off.
2. Remove the bearing and shims remove the circlip (5). Support the carrier on blocks and knock out the shims and bearings from housing (10) by pushing from the front. NOTE which bearing is removed first as one bearing is roller and other is ball type. Inspect and renew if necessary.

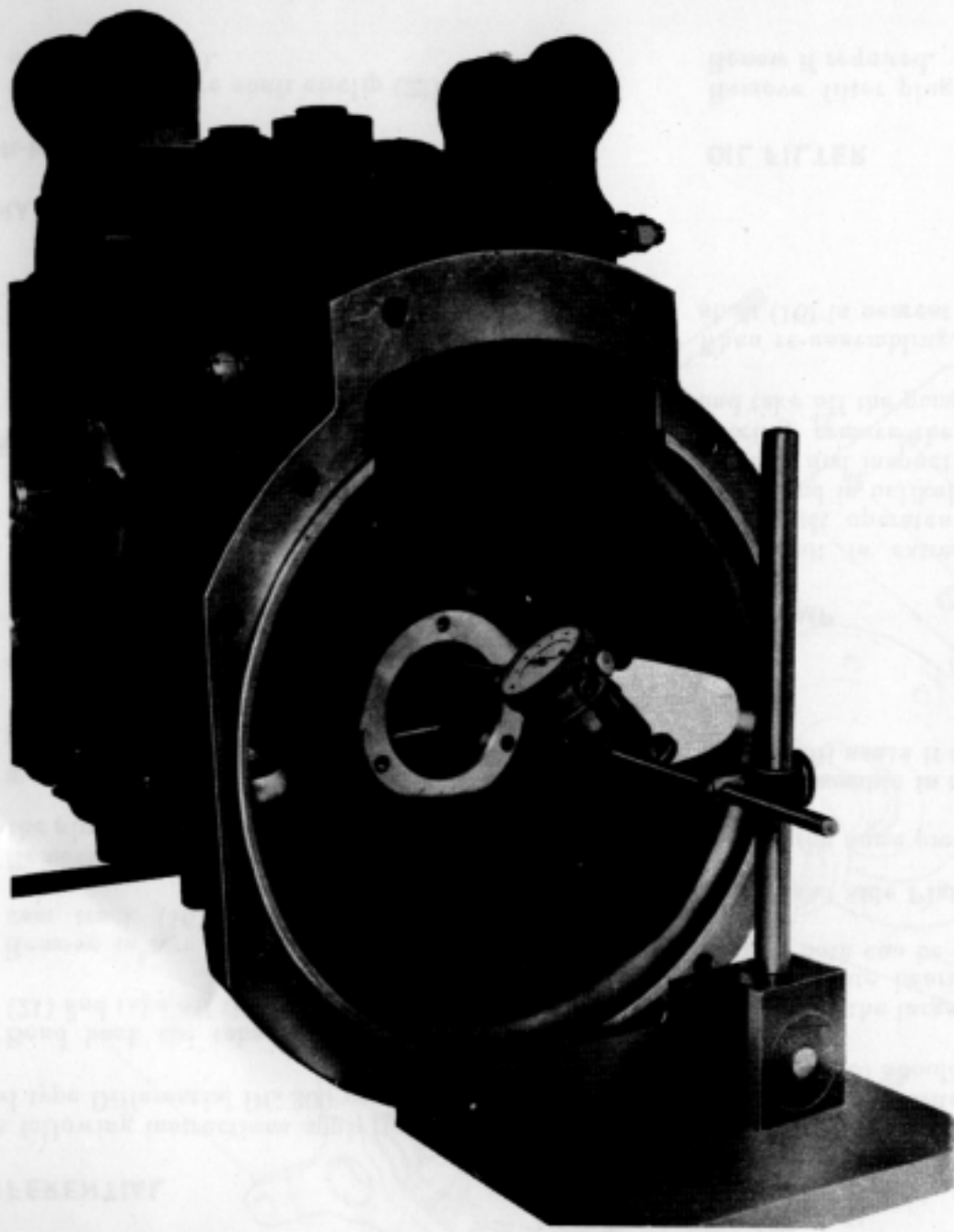

Fig. 3. The Hewland setting gauge in position

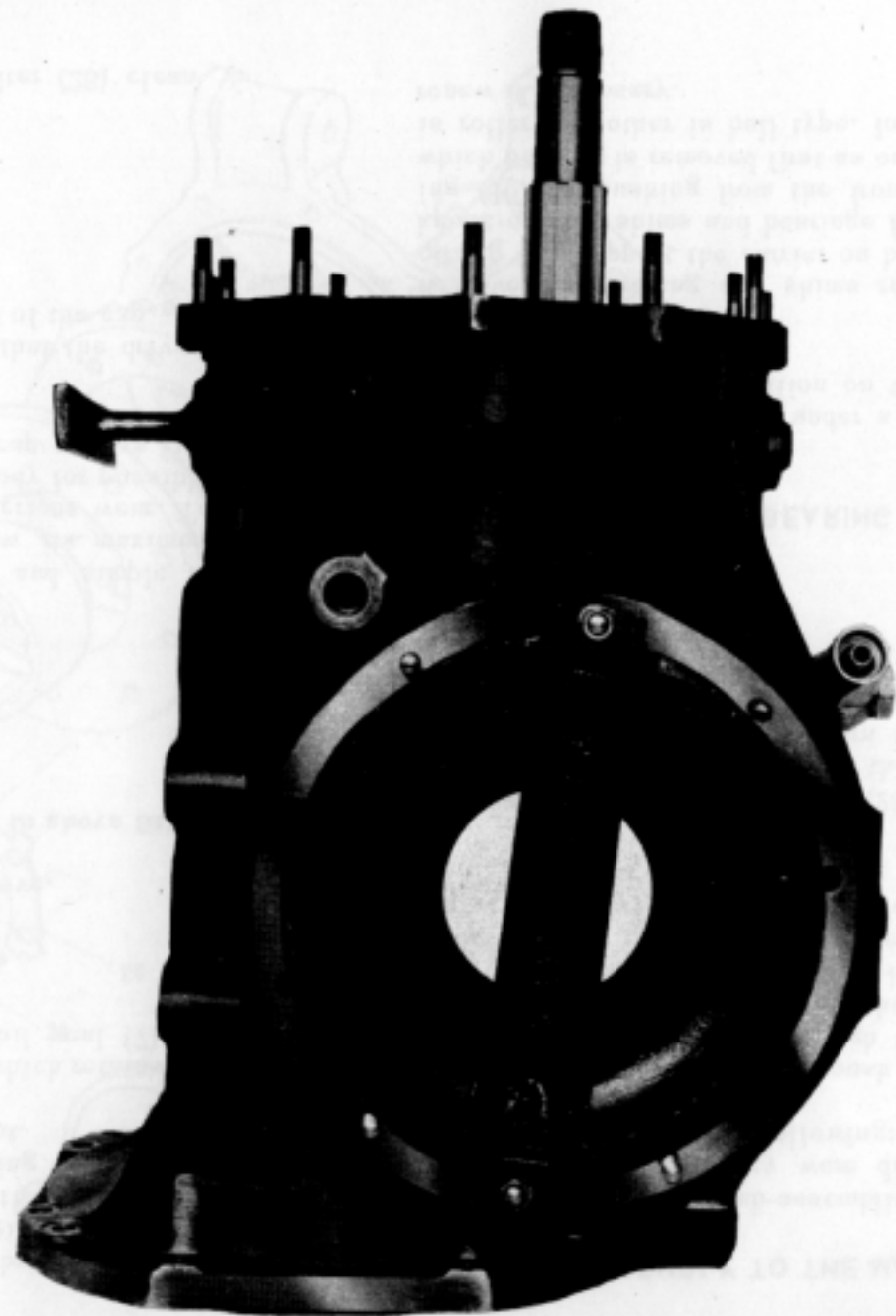

Fig. 4. How the dial recording micrometer is used to measure backlash

# Fitting a new Crown Wheel and pinion

The crown wheel and pinion are supplied as a pair, precision matched and lapped. Each pair is individually tested and passed as perfect before leaving the factory, and neither part should ever be replaced without the other.

Setting up can be done in the usual way, using engineer's blue. A faster and more positive method, however, is to use the new Hewland Setting Gauge. Procedure is as follows:-

## SETTING UP

### USING THE HEWLAND SETTING GAUGE

Proceed as follows:-

1. Using dummy bearings (we can supply these if required) make up bearing housing assembly. Inset circlip (5) into assembly housing.
2. Press the bearings into the housing and by means of a feeler gauge determine the clearance at the end of the housing.
3. Add 0.002" above the feeler gauge reading to allow for slight pre-load on bearings.
4. Remove the circlip and top bearing, insert shims and replace bearing and circlip.
5. Insert spacer (4) onto pinion and slide on the bearing housing assembly.
6. Slide on hubs and tighten up pinion nut.
7. Warm up the main case and insert the pinion assembly.
8. Replace the allen cap screws (9). Due to a slight "float" on the dummy bearings support

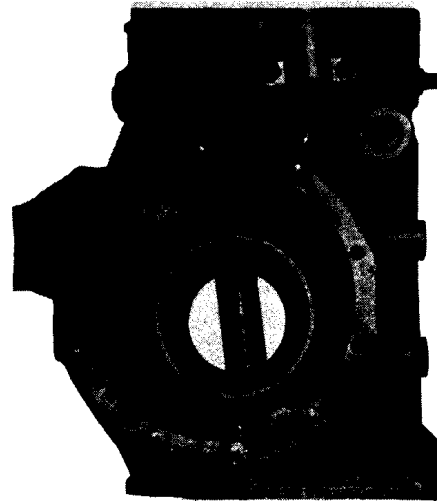

Fig. 5. Pinion in Setting Gauge

the pinion tail by putting on the bearing carrier complete with the pinion tail bearing.

### TO CHECK PINION DEPTH

9. Put setting gauge in position in place of side plate of main case, bolt across the face.
10. Using a feeler gauge, determine the clearance between the setting gauge and pinion. The distance between the pinion and the setting jig must agree with the figure marked on the new pinion. This is adjusted by means of the pinion spacer (4).
11. Remove the setting gauge from the main case.
12. Remove the pinion bearing carrier assembly. Assemble the new bearings with the shims from the dummy bearings.
13. Press the bearing carrier assembly onto the pinion.

14. Warm up the main case. Re-insert the pinion assembly. Smear the allen cap screws with 'Loctite' and tighten up.

### TO ADJUST THE PRE-LOAD

1. Assemble differential unit, using the new crown wheel and solid dummy bearings in place of the two inner differential bearings (11). The thickness of the shims is critical. If they have to be renewed make sure they are replaced with shims of same thickness as the originals.
2. Assemble the differential unit and side plates to the main case. Hold up, including tie bars, to normal tension.
3. Now turn the pinion by hand to test the pre-load. Adjust by means of shims until satisfactory.

NOTE: Turn the pinion with hubs removed. Using reasonable effort it should be possible to turn it by gripping the splines, but more effort will be needed with dummy bearings than with real ones. Make sure there is some evidence of backlash. Absence of backlash will give a false impression of pre-load.

### TO ADJUST THE BACKLASH

For this operation you will require a post-mounted dial indicator with an extended probe (Fig 4).

1. Remove the solid dummy bearings from the differential unit and replace them with dummy bearings. (Real bearings with increased tolerances for easy substitution).

Continued on next page

**Fitting new Crown Wheel and Pinion**  
Continued from previous page

2. Insert the probe of the dial indicator through spigot housing until it touches one of the teeth of the crown wheel (Fig 4) Note the reading on the dial indicator. Turn pinion by hand to rotate crown wheel, and take at least 12 readings. (14 readings are standard practice in our own workshops). Minimum reading should be .004".
8. To increase or decrease backlash, change shims from one side of the differential to the other. But remember that, once the pre-load has been set, you can use only the shims that are already there. Continue to test until satisfactory.

**RE.ASSEMBLE AS FOLLOWS:-**

4. Press inner bearings onto differential assembly.
5. Warm up one side plate, insert oil seal, side plate bearing and circlip.
6. Press the drive shaft into the side plate and retain with circlip.
7. Insert shim or shims, and outer bearing track. Place a heavy weight on bearing to flatten out shims.
8. Repeat for the other side plate. After cooling, assemble one side plate to the main case. complete the assembly of the differential and **drive** unit as described above.

N.B. If renewing the differential carrier bearings, make certain that the width of the dummy **bear-**ings used for pre-load and backlash are the same width as the new bearings.

**BACK AXLE PARTS LIST**

ILLUS. NO.	DESCRIPTION	QTY	PART NUMBER
61	7/16" Nyloc Nut	6	FT 2195
02	Bolt Drive Shaft	6	FT2192
B3	Drive Shaft L.H. or R.H.	2	DG219
04	5/16" Nyloc Nut	31	FT 2013
B5	5/ 1 6" Washer	31	FT 2027
B6	Side Plate		DG 205
87	Oil Seal	2	LG 2054
B8	Bearing	2	LG 2053
B9	Circlip	2	LG 2052
B10	Shim Sideplate	Various	HD 2061
B11	Bearing	2.	DG 2051
B12	Limited slip Diff.		DC 212
B13	Plunger Carrier		DC 214
B14	inner Cam Track		LG 216
B15	Plunger	8	LG217
B16	Outer Cam Track		LG215
B17	Outer Housing		DC 213
B18	Sideplate		DG 206
B19	<i>Crown</i> Wheel & Pinion		See Chart Main Case
B20	Tab Washer (Optional)	5	FT 2212
B21	Crown Wheel Bolt	10	FT 2211
B22	Circlip	2	LG 2191
B23	Drive Shaft Bolt	8	LG 2193
B24	Drive Shaft L.H. or R.H.	2	DG 218
B25	Nyloc Nut 3/8"	8	FT 2196
B26	Tie Bar	2	LG 262
B27	Tie Bar	2	DC 262

# ALTERNATOR DRIVE AND PARTS LIST

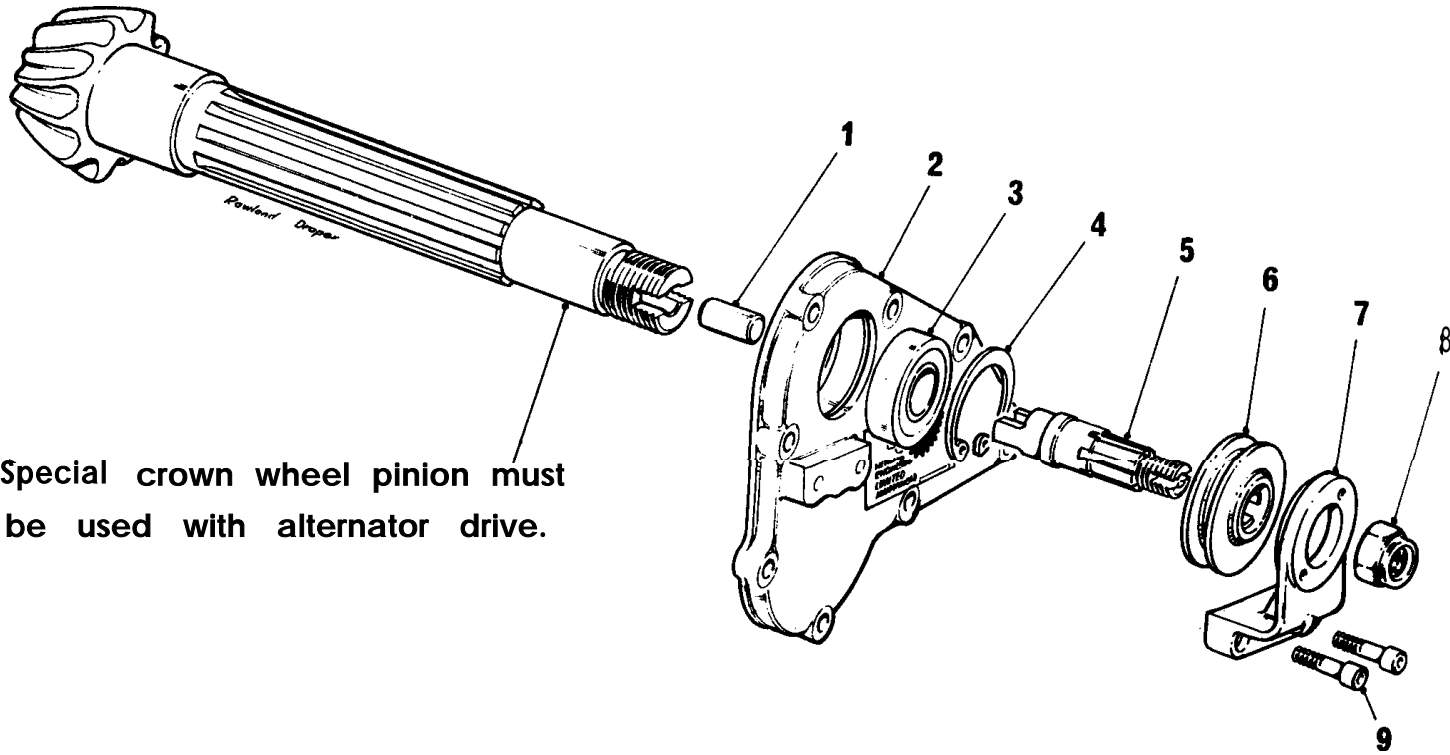

ILLUS. No.	DESCRIPTION	QTY	PARTNUMBER
D1	Support Plug	1	DG 2044A
D2	End Cover	1	DG 204 A
D3	Bearing	1	FT 2041 A
D4	Circlip	1	FT 2042 A
D5	Drive Shaft	1	DC 2045 A
D6	Pulley	1	FT 2046 A
D7	Bracket	1	FT 2049 A
D8	Nut	1	FT 2043 A
D9	Screws	2	FT 2047 A

# OIL PUMP AND PARTS LIST

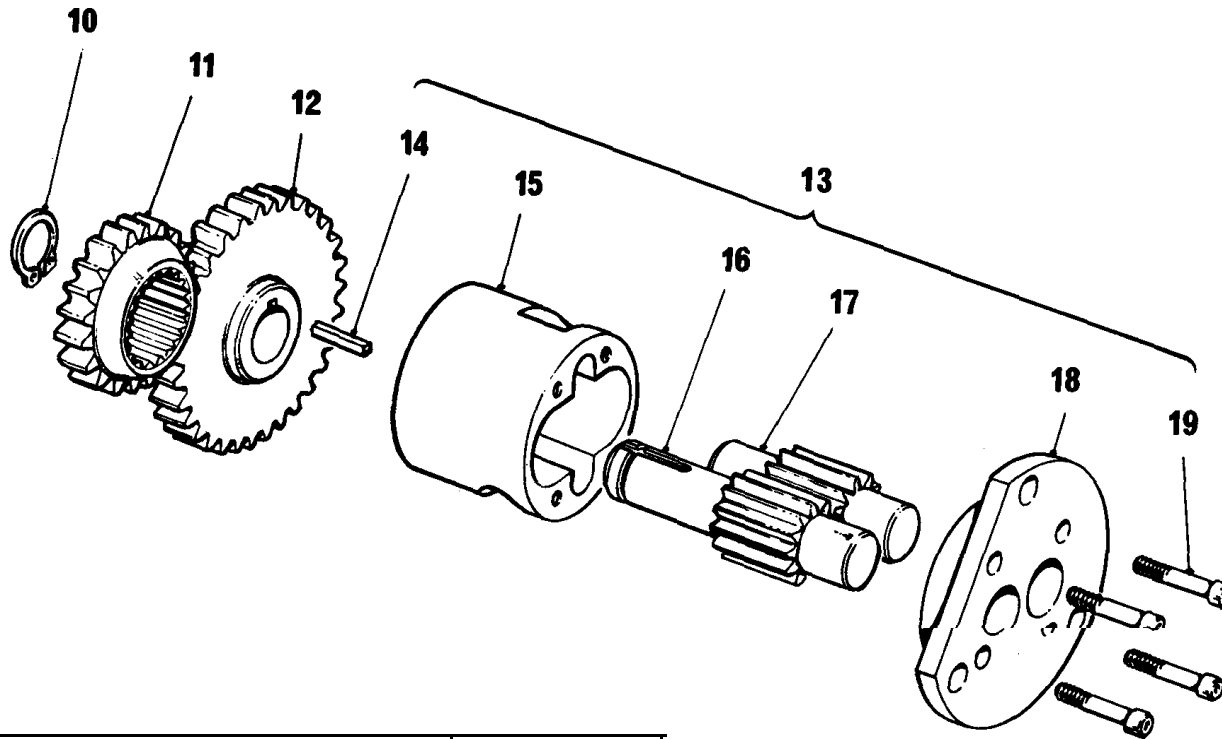

ILLUS. No.	DESCRIPTION	QTY	PART NUMBER
D10	Circlip	1	DG 2658
D11	Gear Clutch Shaft	1	DC 2659
D12	Gear Oil Pump	1	DC 2657
D13	Oil Pump Assembly	1	DG 265
D14	Woodruff key	1	DC 2656
D15	Oil Pump Body	1	DC 2652
D16	Gear	1	DC 2655
D17	Gear	1	DC 2654
D18	Pump Cover	1	DG 2653
D19	Screws	4	DC 2651
	Spare Ratios		A Pair
Special Machined Bearing Carriers, Selector Finger Housing, Crown Wheel and Pinion, MUST BE USED WITH ALTERNATOR DRIVE.			

## ADAPTOR PLATES

A wide selection of adaptors are stocked prices and availability on application.

## MISCELLANEOUS

Hylomar, Anon setting jointing compound  
 Rubber Coupling 5# P.C.D.  
 Gasco ML, Metal Locking Sealant  
 Forgings suitable for making up drive shafts to match the 5% P.C.D.  
 Rubber Coupling Part No. SK 28  
 Setting Jig Less Pinion and Bearing  
 Dummy Bearings for setting C.W.P.  
 Clutch Aligning Tool Specify Clutch